

PetroQuip’s **DeSander XL** separates sand and other solids from the produced fluid before it enters the ESP. The vortex created inside the tool pushes sand and solids down into a sump or tail pipe below. Unique design has no internal fins which creates longer tool life.

Advantages and Features

- Extends the life of the ESP by reducing the sand and other solids from the produced fluid
- One size for all flow rates
- No internal fins to erode
- Available with integral cup packer or run below standard retrievable packer
- All internal components hardened with Boron and Tungsten Carbide to reduce erosional wear and prolong life
- Minimal pressure drop through the tool
- Multiple weight tubing sizes and weights serviced by the same tool by changing packer cups

DeSander XL with Cup Packer

SandStorm Size	Tubing Size (in)	Thread	Material	OD (in)	OAL (in)
400	2-7/8	2-7/8" EUE	P110, 13Cr	4.00	20

DESANDER XL

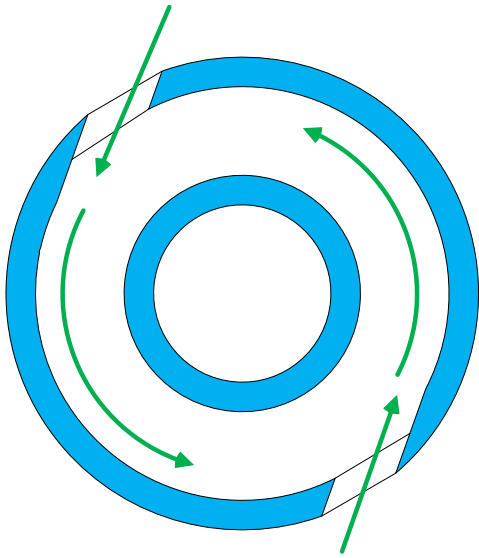

Flow enters through a port tangentially here. The way the flow enters creates the vortex that starts the separation of the heavy solids from the fluid.

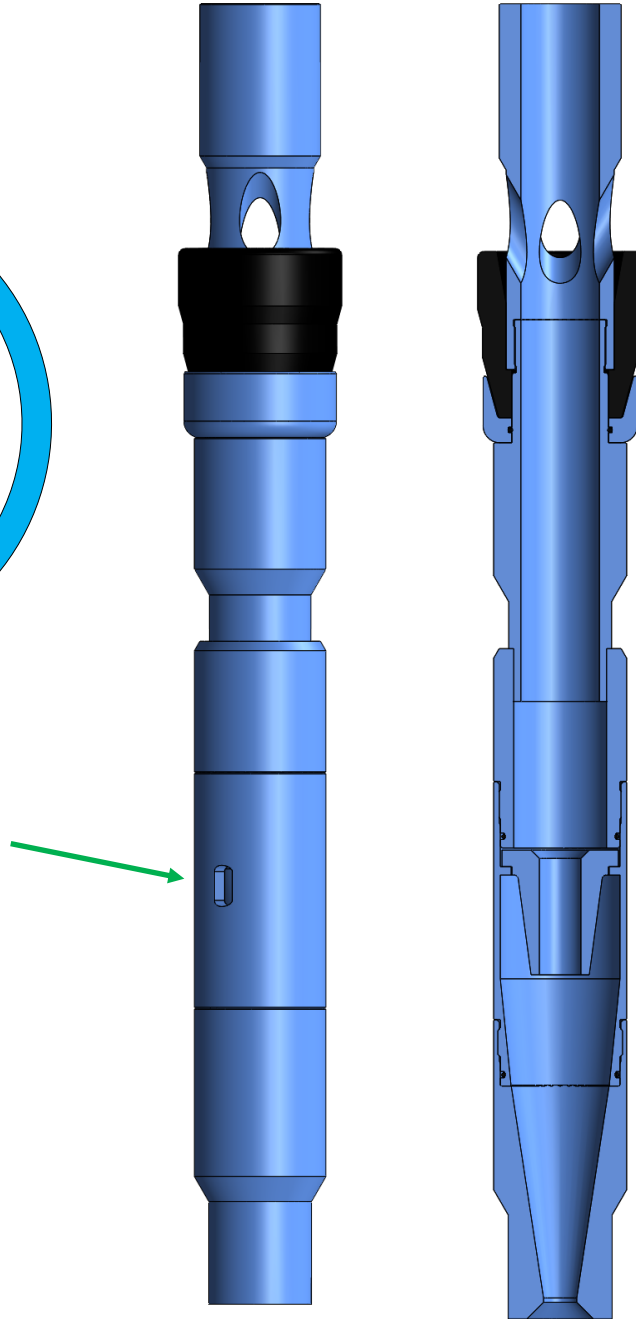

DESANDER XL



As the flow enters the ports and starts to spin (black is both sand and produced fluids), the heavier sand particles are pushed to the ID of the DeSander XL, and the lighter (green) produced fluids are pushed to the center of the DeSander XL. There becomes two separate cyclones of lighter and heavier fluids and particles spinning. The heavier (brown outer cyclone) is pushed down the cone into the sump below. The lighter (green inner cyclone) is sucked up the hole by the ESP above.

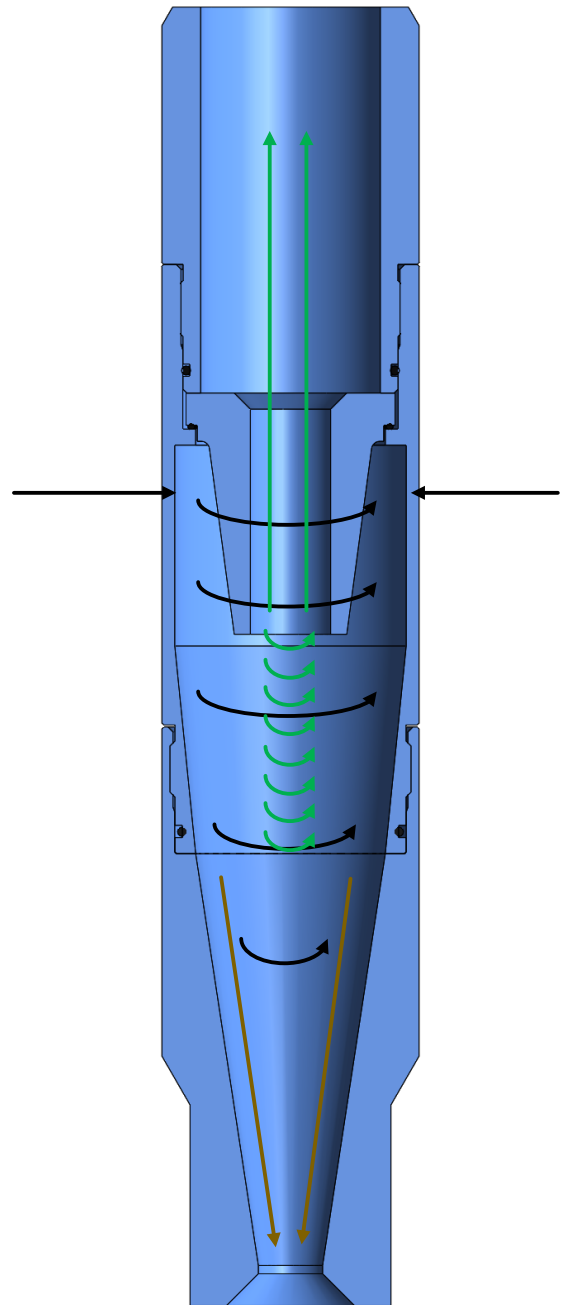

DESANDER XL



Run Separately
with a Retrievable
Packer

Run with the ESP
and a Cup Packer

