



PetroQuip’s SandStorm-S separates sand and other solids from the produced fluid before it enters the Sucker Rod Pump (SRP). The vortex created inside the tool pushes sand and solids down into a sump or tail pipe below. The unique design has no internal fins or baffles which creates longer tool life. The geometry design has been optimized for the lower flow rate of an SRP.

Advantages and Features

- Effective flowrate range 50—800 bbl/day
- Over 90% efficient
- Extends the life of the SRP by reducing the sand and other solids from the produced fluid
- One size for all SRP flow rates
- No internal fins or baffles to erode
- All internal components hardened with Tungsten Carbide to reduce erosional wear and longer tool life
- Minimal pressure drop through the tool

SandStorm Size	Tubing Size (in)	Thread	Material	OD (in)	OAL (in)
400	2-7/8	2-7/8" EUE	P110, 13Cr	4.00	20

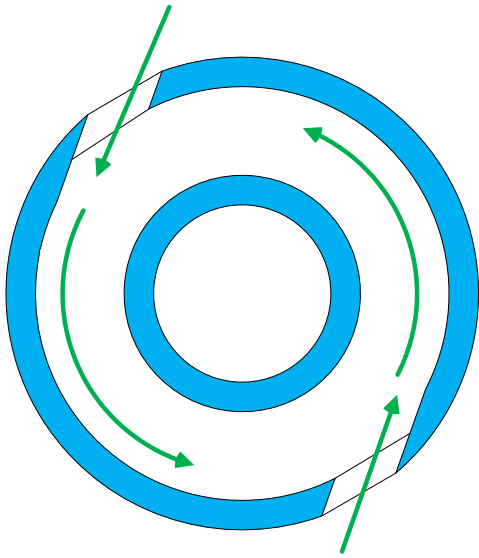

Flow enters through a port tangentially here. The way the flow enters creates the vortex that starts the separation of the heavier sand and solids from the fluid.

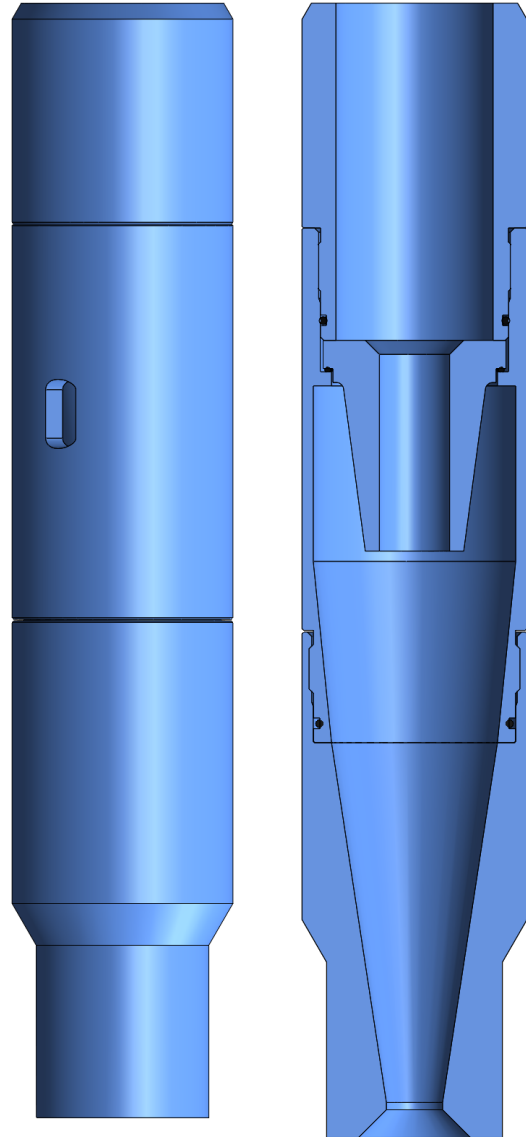

As the flow enters the ports and starts to spin (black is both sand and produced fluids), the heavier sand particles are pushed to the ID of the SandStorm-S, and the lighter (green) produced fluids are pushed to the center of the SandStorm-S. There becomes two separate cyclones of lighter and heavier fluids and particles spinning. The heavier (brown outer cyclone) is pushed down the cone into the sump below. The lighter (green inner cyclone) fluids are lifted up the tubing by the SRP above.

